



M/T “DUZGIT INTEGRITY”

IMO II CHEMICAL / OIL TANKER

Vessel Particulars

Classification	: BV – Ice IA, IMO II
Built	: 2008
Builder	: Marmara Shipyard, Turkey
Flag	: Malta
Port of Registry	: Valletta
IMO Nr.	: 9380415
Service Speed (%85 MCR)	: 14.3 Knots
Economic Speed	: 13.0 Knots
Cons. (1) (%85 MCR)	: 17.00 t/day
Cons. (2)	: 14.00 t/day
Stern Line	: Yes
Deck Crane Capacity	: 16 m / 5 ton
Communication	: Sat, GSM, Fax, Tlx, e-mail
Main Engine	: MaK 9M32C/4500 KW
Bow Thruster	: HRP 500 kW

Main Dimensions

Summer Deadweight	: 10,735 mts
Winter Deadweight	: 10,371 mts
Summer Draught (SW)	: 7.98 m
Winter Draught (SW)	: 7.81 m
Length Overall	: 131.85 m
Moulded Breadth	: 18.90 m
Ballast Capacity	: 4,550 m ³
Cargo Capacity (98%)	: 12,596 m ³
Gross Tonnage	: 7833
Net Tonnage	: 3626
SBT Tonnage	: 1315
Light Weight	: 4,081 mts
Distance KTM	: 35.85 m
Parallel Body Length (SDWT)	: 55.70 m

M/T "DUZGİT INTEGRITY"

ALL VOLUMES ARE GIVEN IN M³ AT 98%

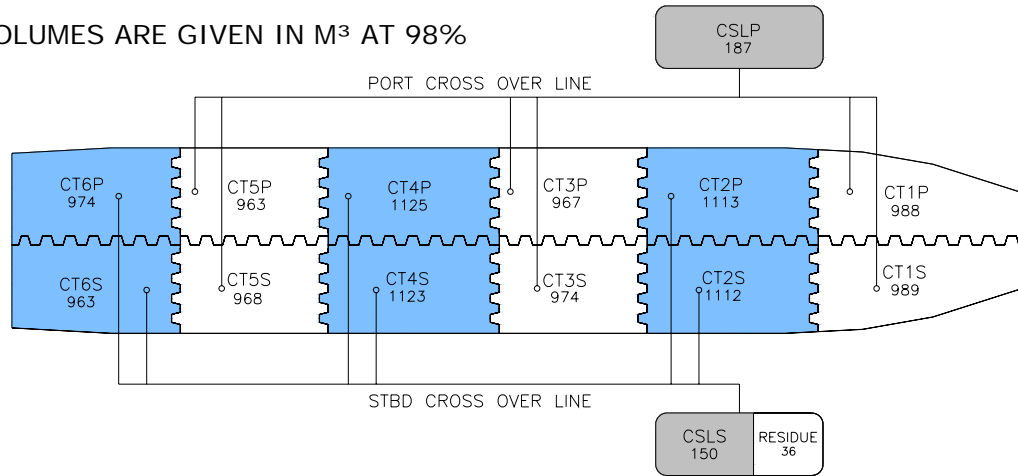

Cargo Tanks						
Tank no	m3 98%	Lining	Pump Capacity	Max SG	IMO	Max Heat Capacity
CT1P	988	Marine Line	375 m ³ /h	1.54	2	80 deg C
CT1S	989	Marine Line	375 m ³ /h	1.54	2	80 deg C
CT2P	1113	Marine Line	375 m ³ /h	1.54	2	80 deg C
CT2S	1112	Marine Line	375 m ³ /h	1.54	2	80 deg C
CT3P	967	Marine Line	375 m ³ /h	1.54	2	80 deg C
CT3S	974	Marine Line	375 m ³ /h	1.54	2	80 deg C
CT4P	1125	Marine Line	375 m ³ /h	1.54	2	80 deg C
CT4S	1123	Marine Line	375 m ³ /h	1.54	2	80 deg C
CT5P	963	Marine Line	375 m ³ /h	1.54	2	80 deg C
CT5S	968	Marine Line	375 m ³ /h	1.54	2	80 deg C
CT6P	974	Marine Line	375 m ³ /h	1.54	2	80 deg C
CT6S	963	Marine Line	375 m ³ /h	1.54	2	80 deg C
CSLP	187	Marine Line	100 m ³ /h	1.54	2	80 deg C
CSLS	150	Marine Line	100 m ³ /h	1.54	2	80 deg C
Total	12596	Marine Line				
RESIDUE	36	Marine Line	10 m ³ /h	1.54	2	80 deg C

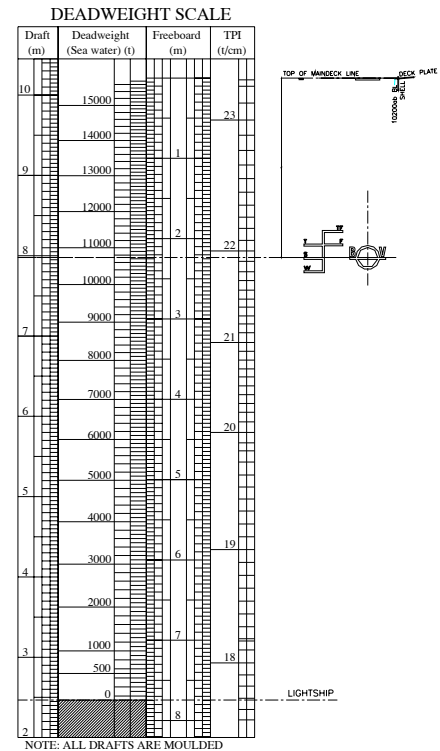

Manifold

Distance Bow-Center manifold	: 68.20 m
Distance Stern-Center manifold	: 59.50 m
Inboard from ships side	: 4.80 m
Height above deck	: 3.80 m
Height above waterline (loaded)	: 6.00 m
Height above waterline (in ballast)	: 8.90 m
Highest allowable pressure	: 16 bar
Manifold flanges	: 4"-6"-12" ANSI
Segregation for Cargo Lines	: 12 (CT) + 2 (SLP)

Nitrogen

Nitrogen plant producing 770 Nm³/h

Inert Gas System

Inert Gas plant producing 1875 m³/h

Cargo Pumps

Framo deepwell pumps in all cargo tanks

Pumping rate is each 375m³/h 110 mlc.

Sp. Gravity: 0,8 Viscosity : 1,0 cst

Cargo Rating

Total discharging rate 1500 m³/h

Total loading rate 1600 m³/h

Cargo Heating

316L Stainless steel heating coils (Double Loop)

Ballast System

Hyd. deepwell pumps 2 x 400m³/h = 800m³/h



DÜZGİT GROUP

DS TANKERS LTD.

DS TANKERS LTD. c/o DÜZGİT GROUP
Aydintepe Mahallesi, Yakut Sok. No: 11
Tuzla 34947 İstanbul - TURKEY

Phone : +90 216 4936064

Fax : +90 216 4936066

e-mail : management@dstankers.com